

Fuzzy Collision Threat Parameters Area (FCTPA) - a new display proposal

R. Szłapczyński

Gdańsk University of Technology, Gdańsk, Poland

ABSTRACT: The paper introduces a visualization method that enables the navigator to estimate an encounter situation and choose collision avoidance manoeuvre if necessary. It is based on the CTPA method and offers new features: fuzzy sectors of forbidden speed and course values and the possibility to use any given ship domain. The method is fast enough to be applied in the real-time decision-support system.

1 INTRODUCTION

Traditional displays used in collision-avoidance systems were based on the relative Cartesian coordinate system, with the own ship in the centre of it and X and Y coordinates denoting the relative positions of targets. Their functionality was limited to showing all targets within a certain range and indicating the targets that were considered to be dangerous on the basis of computations performed by the system. Some of them additionally visualized Predicted Areas of Danger (PAD) and the resulting necessary course alterations. What these displays failed to visualize was the nature of collision risk: the colliding combinations of courses and speeds of the own ship and the dangerous targets. Visualizing these forbidden combinations of course and speed (instead of course only) has been introduced by Lenart as a part of Collision Threat Parameters Area (CTPA) method in (Lenart 1982). However, the display according to Lenart naturally assumes using a pre-defined safe distance D_S as a main safety parameter and $DCPA$ as a collision risk measure. Therefore it cannot be used for precise visualization of the necessary manoeuvres when domains other than circle-shaped are assumed. The author of the paper has combined the following ideas: double coordinate system used in CTPA, a fuzzy ship domain (Pietrzykowski 2001) and approach factor f_{min} – a new measure of collision risk defined by the derived from the concept of a ship domain (Szłapczyński 2006). Approach factor f_{min} is defined as the scale factor of the largest domain-shaped area that is predicted to remain free of other ships throughout the whole encounter situation.

The result is a new visualization method called Fuzzy Collision Threat Parameters Area (FCTPA). It is based on Collision Threat Parameters Areas method and extends it so as to handle any given domain, including fuzzy domains. The rest of the paper is organized as follows. Section 2 briefly describes the CTPA method. In Section 3 the new method of visualization – FCTPA is presented. In Section 4 an example of planning the last chance manoeuvre using the FCTPA method is provided. Finally Section 5 is a summary of the paper.

2 COLLISION THREAT PARAMETERS AREAS (CTPA)

In (Lenart 1982) a collision threat is defined as a target ship for which the following condition holds:

$$DCPA < D_S \quad (1)$$

The method uses a double Cartesian coordinate system where the horizontal axis represents both the X coordinate of position and VX coordinate of speed and the vertical axis represents both the Y coordinate of position and VY coordinate of speed. The relation between the position and speed coordinates is as follows:

$$\begin{aligned} x &= V_x * \tau, \\ y &= V_y * \tau, \end{aligned} \quad (2)$$

where τ is a fixed time value, for example 12 minutes.

The Collision Threat Area for a single target ship is defined as an area in the abovementioned system of coordinates that fulfils the following conditions:

- placing the tip of the own speed vector V within this area would result in violating the safe distance D_S between the own ship and the target,
- placing the tip of the own speed vector V outside this area would result in keeping the safe distance D_S between the own ship and the target.

The Collision Threat Area for a group of target ships is defined as a superposition of the Collision Threat Areas obtained for each of the targets separately.

The formula for the two straight lines determining the boundaries of the CTPA for a given single target is as follows:

$$\begin{aligned} y &= a_1 x - b_1 \tau \\ y &= a_2 x - b_2 \tau \end{aligned} \quad (3)$$

where the coefficients are given by the formulas:

$$\begin{aligned} a_1 &= \frac{x_r y_r + D_S \sqrt{x_r^2 + y_r^2 - D_S^2}}{x_r^2 - D_S^2}, \\ a_2 &= \frac{x_r y_r - D_S \sqrt{x_r^2 + y_r^2 - D_S^2}}{x_r^2 - D_S^2}, \end{aligned} \quad (4)$$

$$\begin{aligned} b_1 &= a_1 V_{tx} - V_{ty}, \\ b_2 &= a_2 V_{tx} - V_{ty}, \end{aligned} \quad (5)$$

where:

- x_r, y_r – coordinates of the relative position of the target ship,
- V_{tx}, V_{ty} – coordinates of the true speed of the target ship.

In practice CTPA is only this part of the determined area, where the condition $TCPA > 0$ holds, since only future collision threats are of interest. Also, in case of a multiple target encounter, the manoeuvres for which the safe distance D_S would be violated after a time longer than the critical time ($DCPA < D_S, TCPA > T_S$) may be allowed, if there is no possibility of avoiding all targets with just one manoeuvre. This means that the tip of the own speed vector may be conditionally placed within this part of the CTPA, for which $TCPA > T_S$.

When applied to the graphical display, the CTPA method enables the operator to choose manually a safe own speed vector in a very easy way – it is enough to choose a point outside the CTPA and read its speed coordinates. The method is summarized by Figure 1.

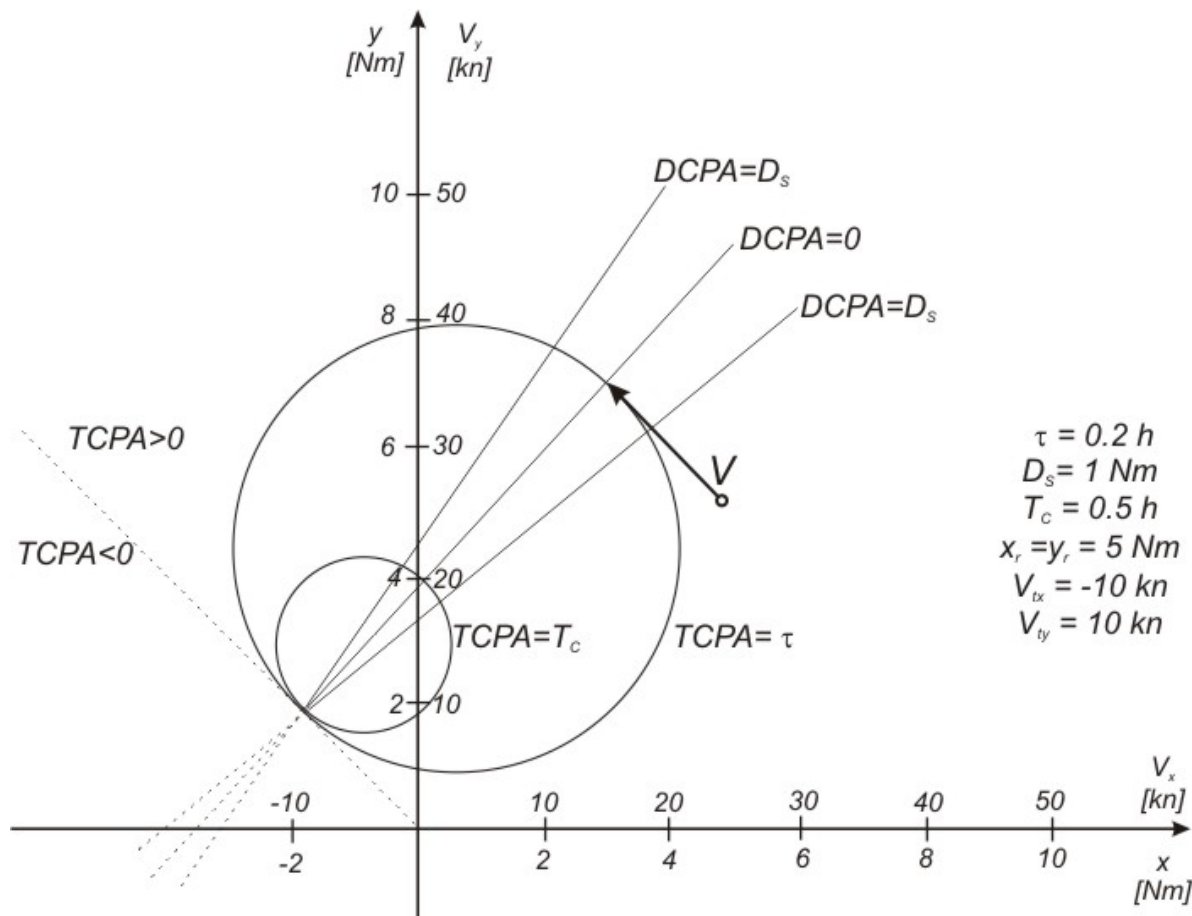

Fig. 1. The Collision Threat Parameters Areas method

3 FUZZY COLLISION THREAT PARAMETERS AREA

In this section a visualization tool that has been designed by the author – Fuzzy Collision Threat Parameters Area (FCTPA) is presented. It is based on the same concept of the forbidden area in the double Cartesian coordinate system, but instead of determining the area analytically for a fixed D_S value, it is determined numerically for a given ship domain. It works as follows. For every combination of the own course and speed the resulting f_{min} value is computed. The algorithms used to compute the f_{min} value for given courses, positions and speeds of the own ship and target ships have been presented in detail in (Szlapczynski 2006). Depending on the obtained value, a point in the double Cartesian coordinate system representing a particular combination of the own speed and course is assigned a colour in the following way:

- for $f_{min} < 0.5$ (critical domain violation): black,
- for $0.5 \leq f_{min} < 1$ (domain violation): gradually changing dark grey,
- for $1 \leq f_{min} < 2$ (close encounter): gradually changing light grey,
- for $f_{min} > 2$ (safe passing): white.

Whenever the arrow indicating the end of the own speed vector appears on the dark grey or black background – a collision avoidance manoeuvre should be performed. A safe combination of the own speed and course is represented by the closest white or light grey point on the display. An exemplary situation is presented below. The data for the scenario is given in Table 1. In Figures 2 – 6 the relative positions, relative courses and relative speeds of targets as well as the resulting FCTPA are shown. The domain according to Coldwell (Coldwell 1982) is used here.

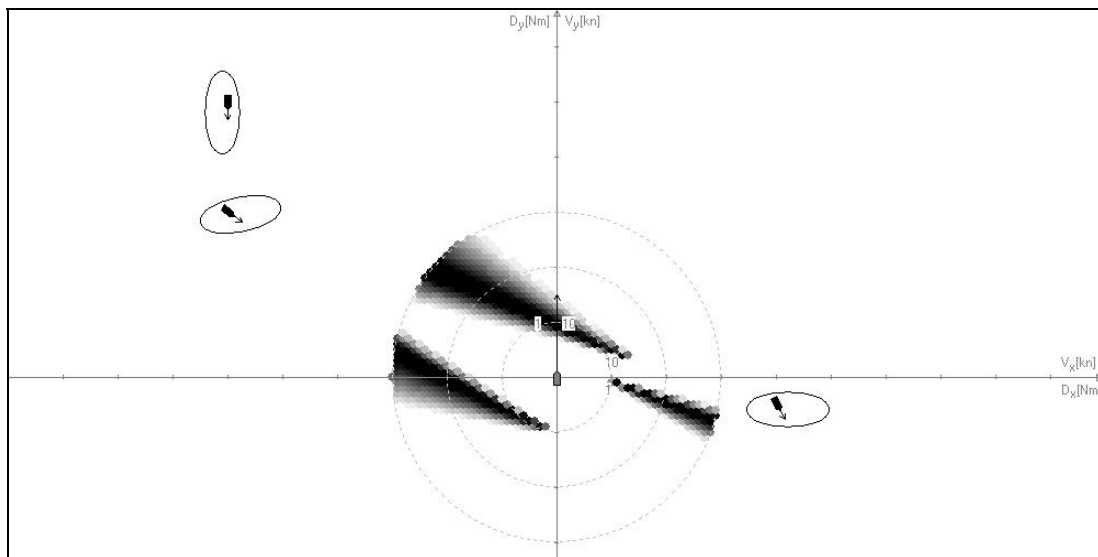

Fig. 2. The FCTPA for the given scenario for the start time ($t = 0$ min.)

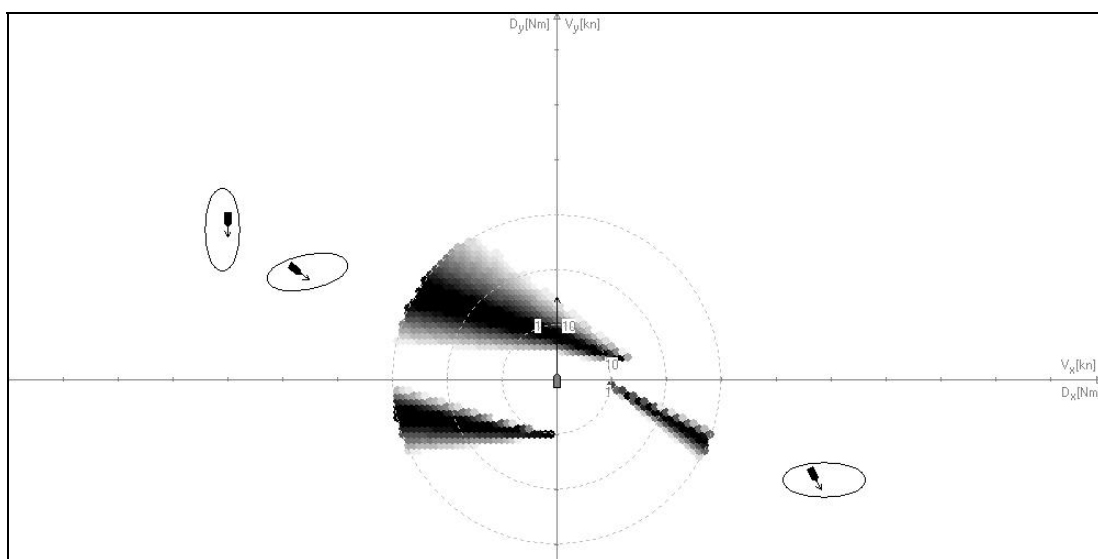

Fig. 3. The FCTPA for the given scenario for the time $t = 5$ min.

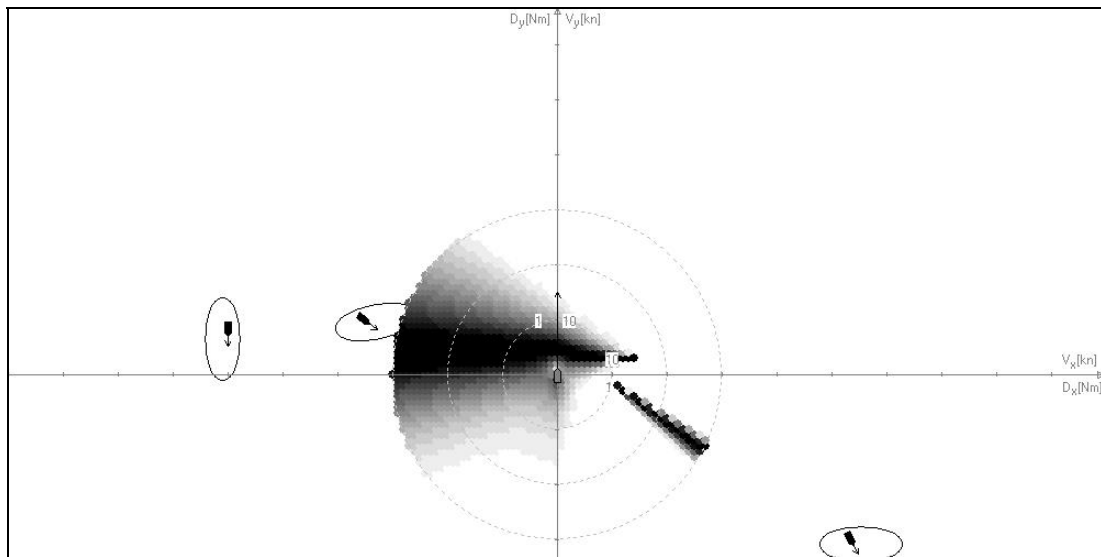

Fig. 4. The FCTPA for the start time of the given scenario for the time $t = 10$ min.

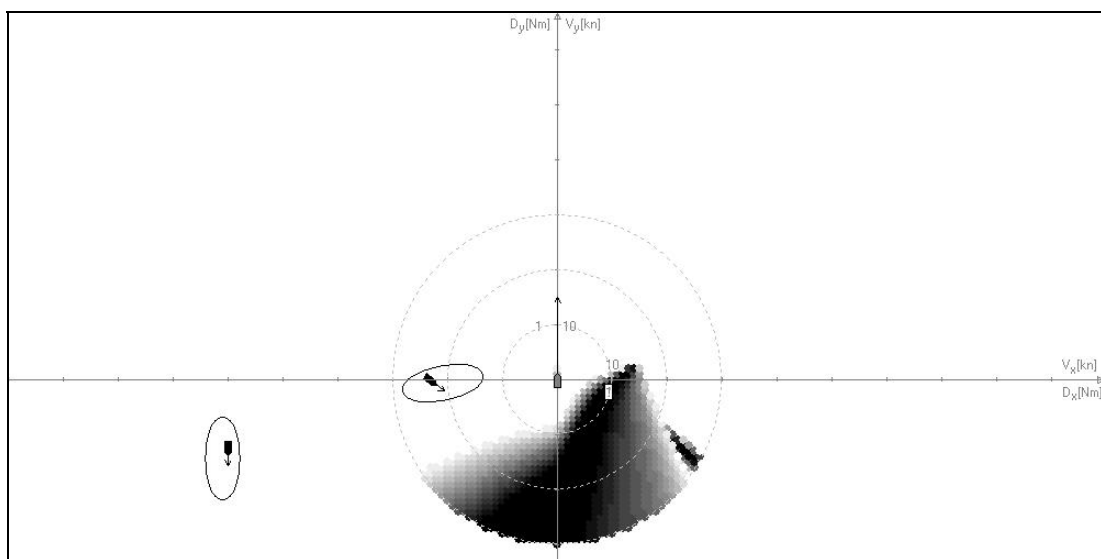

Fig. 5. The FCTPA for the given scenario for the time $t = 15$ min.

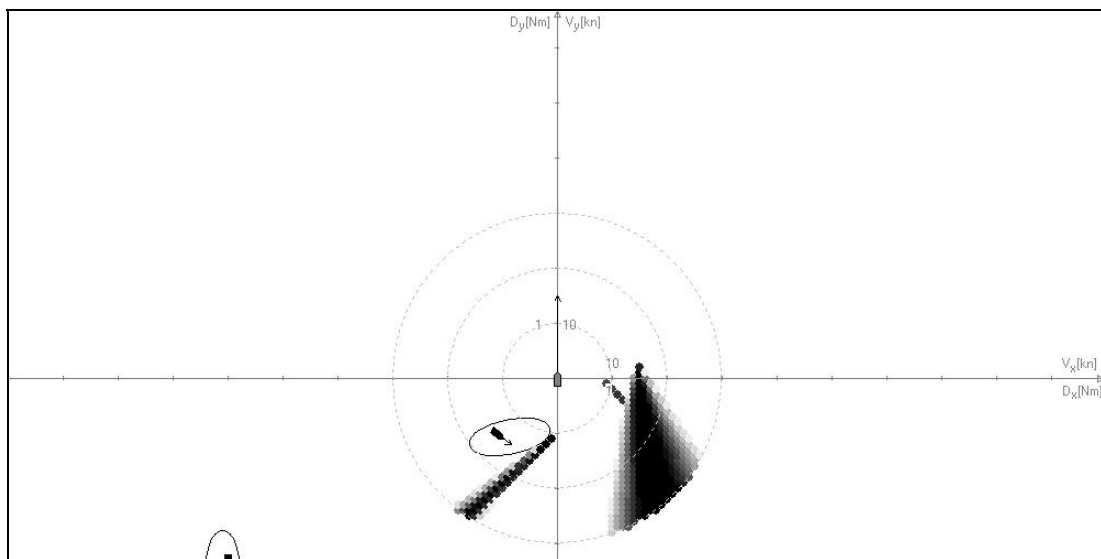

Fig. 6. The FCTPA for the given scenario for the time $t = 20$ min.

Table 1. The positions, courses and speeds of the own ship and the target ships at the start time (decision time 3 min.)

Speed [knots]	Course [degrees]	Position coordinates at the start time	
		x [n.m.]	y [n.m.]
15	0	0	0
8	90	4	-0.5
10	0	-6	5
15	79	-6	3

In Figure 2 the arrow indicating the end of the own ship speed vector is on the light grey area, which means a close but relatively safe encounter with target 3 (no domain violation). In Figure 3 the situation is still safe but the forbidden region has enlarged significantly due to the own ship approaching the target 3. The forbidden region is continuously increasing which is shown in Figure 4. In Figure 5 the forbidden region has changed because the own ship

is currently passing target 3. Once the own ship has passed the target 3, the forbidden region decreases rapidly, which is illustrated by Figure 6.

4 AN EXEMPLARY SCENARIO OF USING FCTPA FOR PLANNING THE LAST CHANCE MANOEUVRE

In this section the situation involving the last chance manoeuvre is presented. It is assumed here, the start data for this scenario is the same as for the situation in section 3, however, after 12 minutes from the start, when the closest target is about 3 nautical miles from the own ship it alters its course unexpectedly in such a way, that the own ship is forced to perform the last chance manoeuvre.

The input data for this scenario is given in Figures 7 -8 and in Table 2. Figure 7 depicts the situation before target 3 altered its course by 41 degrees.

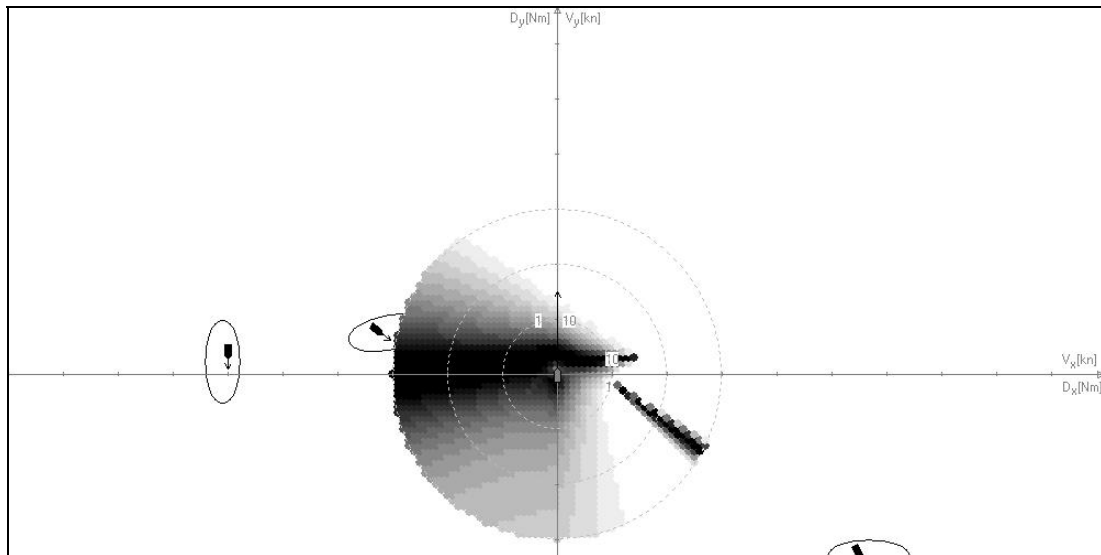

Fig. 7. The FCTPA for the given scenario for the time $t = 11$ min. (before target 3 has altered its course)

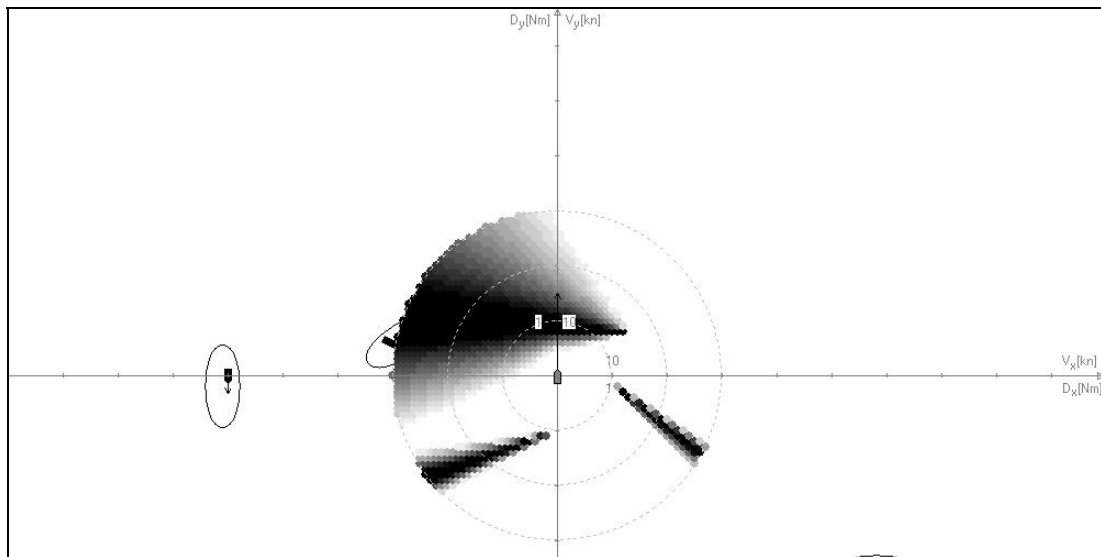

Fig. 8. The FCTPA for the given scenario for the time $t = 12$ min. (after target 3 has altered its course by 41 degrees)

Table 2 presents the data for the situation after target 3 has altered its course (t = 12 min.)

Table 2. The positions, courses and speeds of the own ship and the target ships after target 3 has altered its course (decision time 3 min.)

Speed [knots]	Course [degrees]	Position coordinates at the start time	
		x [n.m.]	y [n.m.]
15	0	0	0
8	90	5.6	-0.5
10	0	-6	0
15	58	-3.1	0.6

Figure 8 depicts the situation after target 3 altered its course by 30 degrees. The end of the arrow indicating the own speed vector is on the dark grey area, which means that there is a significant collision risk (possible domain violation). It might be concluded from Figure 8, that to avoid the collision, the own ship should take one of the following actions within a 3-minute decision time:

- alter its course to the starboard by approximately 75 degrees,
- reduce its speed from 15 to 5 knots,
- alter both its course and speed, for example reduce the speed from 15 to 8 knots and alter its course by approximately 60 degrees to the starboard.

5 SUMMARY

In the paper a visualization method – FCTPA has been introduced. It is based on the CTPA method and offers new features: fuzzy sectors of forbidden speed and course values and the possibility to use any given ship domain. The method enables the navigator to assess an encounter situation and plan a collision avoidance manoeuvre if necessary. It is especially useful for planning last chance manoeuvres because the navigator can choose a combination of course and speed alteration manoeuvre quickly without performing any additional computations.

REFERENCES

- Coldwell T.G. 1982. Marine Traffic Behaviour in restricted Waters, *The Journal of Navigation* vol. 36: pp. 431-444.
- Lenart A.S. 1982. Collision threat parameters for a new radar display and plot technique, *The Journal of Navigation* vol. 36: pp. 404-410.
- Pietrzykowski Z. 2001. Ship Fuzzy Domain on a Straight Section of a Fairway – Comparative Study, The IX International Scientific and Technical Conference on Maritime Traffic Engineering, Szczecin.
- Szlapczynski R. 2006. A unified measure of collision risk derived from the concept of a ship domain, *The Journal of Navigation* vol. 59: pp. 477-490.